

Precipitation Sensor

Instruction for Use

with analogue Intensity Output

5.4103.20.041, 5.4103.20.641, 5.4103.20.741



Dok. No. 021335/07/19

THE WORLD OF WEATHER DATA

Safety Instructions

- Before operating with or at the device/product, read through the operating instructions. This manual contains instructions which should be followed on mounting, start-up, and operation. A non-observance might cause:
 - failure of important functions
 - endangerment of persons by electrical or mechanical effect
 - damage to objects
- Mounting, electrical connection and wiring of the device/product must be carried out only by a qualified technician who is familiar with and observes the engineering regulations, provisions and standards applicable in each case.
- Repairs and maintenance may only be carried out by trained staff or **Adolf Thies GmbH & Co. KG**. Only components and spare parts supplied and/or recommended by **Adolf Thies GmbH & Co. KG** should be used for repairs.
- Electrical devices/products must be mounted and wired only in a voltage-free state.
- **Adolf Thies GmbH & Co KG** guarantees proper functioning of the device/products provided that no modifications have been made to the mechanics, electronics or software, and that the following points are observed:
- All information, warnings and instructions for use included in these operating instructions must be taken into account and observed as this is essential to ensure trouble-free operation and a safe condition of the measuring system / device / product.
- The device / product is designed for a specific application as described in these operating instructions.
- The device / product should be operated with the accessories and consumables supplied and/or recommended by **Adolf Thies GmbH & Co KG**.
- Recommendation: As it is possible that each measuring system / device / product may, under certain conditions, and in rare cases, may also output erroneous measuring values, it is recommended using redundant systems with plausibility checks for **security-relevant applications**.

Environment

- As a longstanding manufacturer of sensors Adolf Thies GmbH & Co KG is committed to the objectives of environmental protection and is therefore willing to take back all supplied products governed by the provisions of "*ElektroG*" (German Electrical and Electronic Equipment Act) and to perform environmentally compatible disposal and recycling. We are prepared to take back all Thies products concerned free of charge if returned to Thies by our customers carriage-paid.
- Make sure you retain packaging for storage or transport of products. Should packaging however no longer be required, please arrange for recycling as the packaging materials are designed to be recycled.



Documentation

- © Copyright **Adolf Thies GmbH & Co KG**, Göttingen / Germany
- Although these operating instruction has been drawn up with due care, **Adolf Thies GmbH & Co KG** can accept no liability whatsoever for any technical and typographical errors or omissions in this document that might remain.
- We can accept no liability whatsoever for any losses arising from the information contained in this document.
- Subject to modification in terms of content.
- The device / product should not be passed on without the/these operating instructions.

Contents

1	Models available	4
2	Application	4
3	Construction and Mode of Operation.....	4
4	Installation.....	5
4.1	Mechanical Mounting	5
4.2	Electrical Mounting for Precipitation Sensor with Cable Gland.....	5
4.3	Electrical Mounting for Precipitation Sensor with Plug Connection.....	6
4.3.1	Plug Mounting	6
4.4	Connecting Diagram	7
5	Taking into Operation	8
6	Maintenance	8
7	Technical Data	9
8	Dimension diagram	10
9	Accessories (Optional)	11
10	EC-Declaration of Conformity.....	12

1 Models available

Order - No.	Measuring value	Electrical Output	Decay time	Operating Voltage	Connection
5.4103.20.041	Precipitation intensity	4...20mA	180 seconds	24V AC/DC	Cable gland
5.4103.20.741	Precipitation intensity	4...20mA	180 seconds	24V AC/DC	7- pole plug connection
5.4103.20.641	Precipitation intensity	4...20mA	50 seconds	24V AC/DC	Cable gland

2 Application

The precipitation sensor serves as measuring instrument for the determination of the instantaneous precipitation intensities (mm precipitation / min.). By integration of the precipitation intensities, the precipitation quantity can be calculated, as well. Control- and warning signals can be derived from the precipitation intensity.

The measuring signal is output as intensity-dependent analogue output value. The dimension of the measurement value output is divided into 4 linear characteristic segments, which show a tenth of the slope of the more sensitive segment.

Thus, it is possible to represent an intensity range from approx. 0,001mm/min. (light drizzle) up to 10mm/min. (extremely heavy rain) with reasonable resolution (quasi-logarithmic output).

3 Construction and Mode of Operation

Precipitation in the form of drizzle, rain, snow, or hail falls through a light band, induced by light diodes, and lead to shadowing effects on the receiving side. The sent light is pulse-modulated so that outside light effects cannot falsify the measurement results. From the extent of shading along with the duration of falling through a factor is calculated that gives the information if there is a precipitation incident or not.

The instrument is equipped with a heating system for extreme weather condition. This avoids ice and snow forming on the housing surface. In addition, the surface retains a temperature of $>0^{\circ}$ by means of a regulated heating.

At the end of the precipitation the analogue output goes in one time of 180sec. (5.4103.20.041, 5.4103.20.741) or 50sec. (5.4103.20.641) to 4mA. If the precipitation starts, the analog output rises again to the measured value.

Housing

The housing consists of polycarbonate, the support of stainless steel. A special coating serves for reducing measurement errors which might arise by drop formation at the housing in the range of the measured distance. This coating must not be removed.

4 Installation

Please Note:

The hydrophilic coating must not be damaged. The electrical connection is to be carried out by experts only. Please open the instrument only with dry ambient conditions. Do not damage the exposed electronics!

Remark:

In order to achieve an optimal electro-magnetic immunity (> 20V/m) please use shielded cable.

4.1 Mechanical Mounting

5.4103.10.xxx

The operating position of the precipitation monitor is horizontal.

The mounting system of the instrument is designed for attachment to a mast. When mounting make sure, that the precipitation can easily reach the sensor field, and that the instrument, while operating, is not exposed to strong vibrations or shocks.

The pictured tube is not included in delivery.

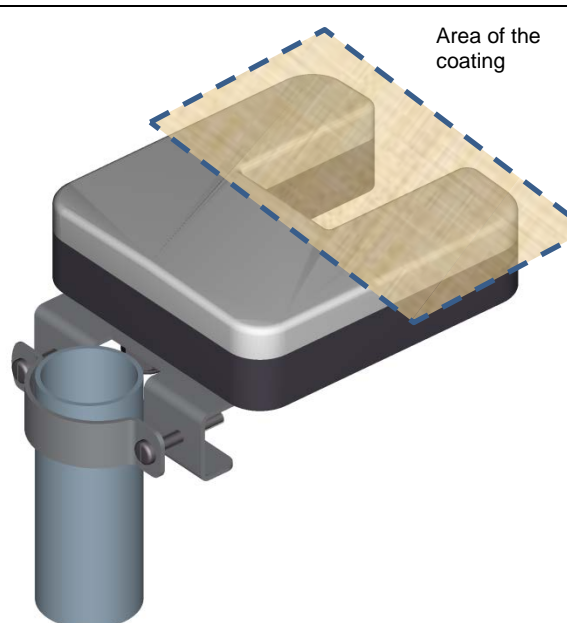

4.2 Electrical Mounting for Precipitation Sensor with Cable Gland

For: 5.4103.20.041, 5.4103.20.641 see circuit diagram in chapter 4.

Process:

- Remove 5 screws at the bottom side of the precipitation monitor.
- Remove upper part (cover). The connecting terminals are the freely accessible.
- Insert a respective prepared cable from the bottom through the cable glands situated in the housing bottom, and connect it to the connecting terminals and shield connector, acc. to circuit diagram.
- Secure cable by cable glands.
- Put on the upper part again and screw it evenly and tightly to the bottom.

Attention:

The fixing screws for the cover must be screwed down with a torsional of **1Nm to 2Nm**.

4.3 Electrical Mounting for Precipitation Sensor with Plug Connection

For: 5.4103.20.741, see circuit diagram in chapter 5.

4.3.1 Plug Mounting

Applies only to instruments with connection „plug“.

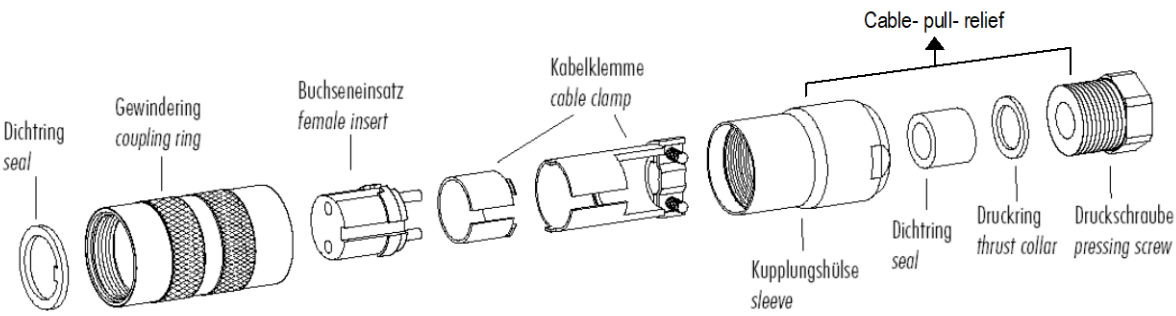
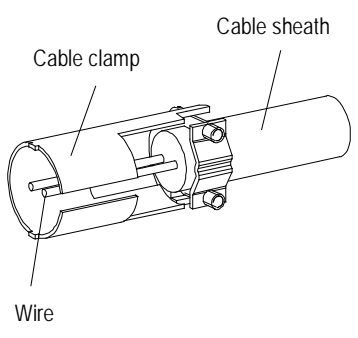
<p>Coupling socket, Typ:Binder, Serial 423, EMC with cable clamp Cable connection: without cable shield</p>	
	
<ol style="list-style-type: none"> 1. Stringing parts on cable acc. to plan given above. 2. Stripping cable sheath 20mm 3. Cutting uncovered shield 20mm 4. Stripping wire 5mm. 5. Soldering wire to the insert 6. Positioning shield in cable clamp. 7. Screwing-on cable clamp. 8. Assembling remaining parts acc. to upper plan. 9. Tightening pull-relief of cable by screw-wrench (SW16 und 17). 	

4.4 Connecting Diagram

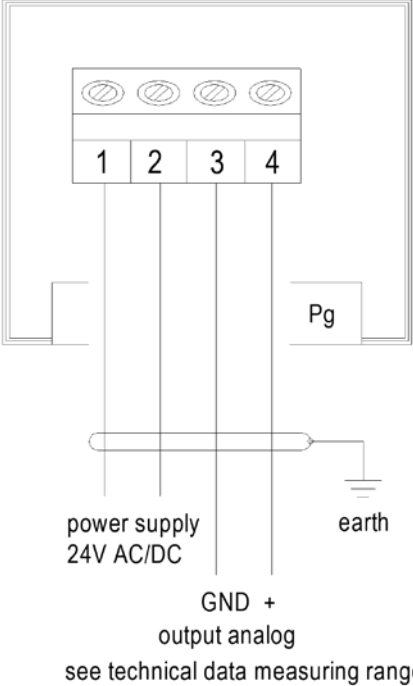
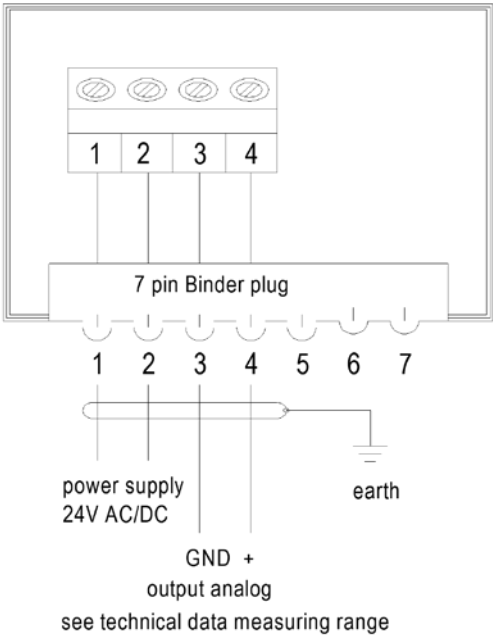
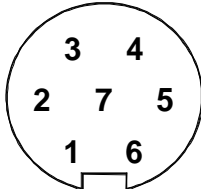
<p>Order-No. 5.4103.20.041 5.4103.20.641</p>	<p>Clamp connection</p>  <p>power supply 24V AC/DC</p> <p>earth</p> <p>GND + output analog see technical data measuring range</p>	
<p>Order-No. 5.4103.20.741</p>	<p>Plug connection</p>  <p>7 pin Binder plug</p> <p>power supply 24V AC/DC</p> <p>earth</p> <p>GND + output analog see technical data measuring range</p>	<p>View on the soldering side of the counter plug.</p> 

Remark:

The cable shield must only be connected on the side of the power supply.

5 Taking into Operation

After the electrical connection has been established, and the case has been screwed, the operating voltage can be switched on. The dimension of the measurement value output is reset when the supply voltage is switched on.

6 Maintenance

The device is maintenance free.

Cleaning:

The pollution and the pollution level is dependent on the location. Therefore, we recommend the unit be checked at appropriate intervals and cleaned if necessary.

For the cleaning should use a damp cloth without chemical cleaning agents are used.

Remark:

The housing is coated in the front section and in the sensor area. This coating must not be damaged.

We recommend to clean (rinse) the instrument only with water, and to blot it with a soft cloth, if necessary. Please take care that no water gets into the instrument. Excessive rubbing might remove the coating.

Events can, possibly, be activated with the cleaning work; they should be considered then with the evaluation / further processing.

7 Technical Data

Measuring Value	Precipitation intensity (mm / min)		
Output	Constant current, depending on measuring value, between 4.0mA and 20.0mA		
Measuring range, Output, Transfer function	Measuring range	Output	Function ¹⁾
Segment 1	0 0.01mm / min	= 4.0 8.0mA	$0,0025 \cdot x - 0,01$
Segment 2	0.01 ... 0.1mm / min	= 8.0 ... 12.0mA	$0,0225 \cdot x - 0,17$
Segment 3	0.1 1.0mm / min	= 12,0 ... 16.0mA	$0,225 \cdot x - 2,6$
Segment 4	1.0 ... 10.0mm / min	= 16.0 ... 20.0mA	$2,25 \cdot x - 35$
max. load	400Ohm		
Active sensor surface	25cm ²		
Minimum drop size	0,2mm		
Operating voltage	24V AC/DC $\pm 15\%$		
Operating current	approx. 350mA @ 20°C ambient temperature max. approx. 1A		
Ambient temperature	-30 ... +60°C		
Protection	IP 65 acc. to DIN 40050		
Weight	0.4kg		
Connection	See model		

¹⁾Function for calculation:

Depending on the segment, where the measured current fits in, the respective function must be applied, wherein for "x" the measured value in mA is entered.

8 Dimension diagram

<p>5.4103.20.041 5.4103.20.641</p>	
<p>5.4103.20.741</p>	<p>Stecker / Plug 65mm</p>

9 Accessories (Optional)

Power Supply Unit	9.3388.00.002	<p>The power supply unit provides for the current supply of the Precipitation Sensor. It supplies the necessary operation voltage for the electronics and the heating.</p> <p>Primary : 230V / 50Hz Secondary : 24V AC / 25VA Housing : synthetic Protection : IP 65 acc. to DIN 40050 Dimensions : 107 x 125 x 100mm Weight : 1,2kg</p>
--------------------------	----------------------	---

10 EC-Declaration of Conformity

Document-No.: 000902

Month: 07 Year: 19

Manufacturer: **ADOLF THIES GmbH & Co. KG**

Hauptstr. 76
 D-37083 Göttingen
 Tel.: (0551) 79001-0
 Fax: (0551) 79001-65
 email: Info@ThiesClima.com

This declaration of conformity is issued under the sole responsibility of the manufacturer

Description of Product: **Precipitation Transmitter**

Article No.	5.4103.10.000	5.4103.10.012	5.4103.10.112	5.4103.10.700
	5.4103.11.000	5.4103.20.041	5.4103.20.641	5.4103.20.741
	5.4103.21.021	5.4103.30.000	5.4103.30.700	5.4103.31.000
	5.4103.32.000			

specified technical data in the document: 021196/05/19; 021334/01/19; 021469/11/09; 021704/07/12
 021767/11/14; 021775/08/14; 021831/03/18; 021833/03/18

The indicated products correspond to the essential requirement of the following European Directives and Regulations:

2014/30/EU	DIRECTIVE 2014/30/EU OF THE EUROPEAN PARLIAMENT AND OF THE COUNCIL of 26 February 2014 on the harmonisation of the laws of the Member States relating to electromagnetic compatibility
2014/35/EU	DIRECTIVE 2014/35/EU OF THE EUROPEAN PARLIAMENT AND OF THE COUNCIL of 26 February 2014 on the harmonisation of the laws of the Member States relating to the making available on the market of electrical equipment designed for use within certain voltage limits
552/2004/EC	Regulation (EC) No 552/2004 of the European Parliament and the Council of 10 March 2004 on the interoperability of the European Air Traffic Management network (the interoperability Regulation)
2011/65/EU	DIRECTIVE 2011/65/EU OF THE EUROPEAN PARLIAMENT AND OF THE COUNCIL of 8 June 2011 on the restriction of the use of certain hazardous substances in electrical and electronic equipment
2012/19/EU	DIRECTIVE 2012/19/EU OF THE EUROPEAN PARLIAMENT AND OF THE COUNCIL of 4 July 2012 on waste electrical and electronic equipment (WEEE)

The indicated products comply with the regulations of the directives. This is proved by the compliance with the following standards:

EN 61000-6-2	Electromagnetic compatibility Immunity for industrial environment
EN 61000-6-3	Electromagnetic compatibility Emission standard for residential, commercial and light industrial environments
EN 61010-1	Safety requirements for electrical equipment for measurement, control, and laboratory use. Part 1: General requirements
EN 50581	Technical documentation for the assessment of electrical and electronic products with respect to the restriction of hazardous substances

Place: Göttingen
 Signed for and on behalf of:

Date: 02.07.2019

Legally binding signature:

issuer:

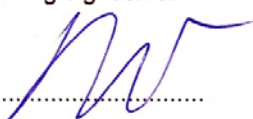

Thomas Stadie, General Manager

Joachim Beinhorn, Development Manager

This declaration certifies the compliance with the mentioned directives, however does not include any warranty of characteristics.
 Please pay attention to the security advises of the provided instructions for use.

**Please contact us for your system requirements.
We advise you gladly.**

ADOLF THIES GMBH & CO. KG

Meteorology and environmental metrology
Hauptstraße 76 · 37083 Göttingen · Germany
Phone +49 551 79001-0 · Fax +49 551 79001-65
info@thiesclima.com

www.thiesclima.com

